

Place tracks

From IBF-Wiki

This article is part of an introduction tutorial called CrashCourse2

Download this article as PDF-File

The placement of tracks can be done manually or by the use of one of the TARGET autorouters, in this case we use the "Hybrid autorouter" in layoutmenu "Actions". Also the keyboard key [r] or the function key [F9] will launch the Hybrid Autorouter.

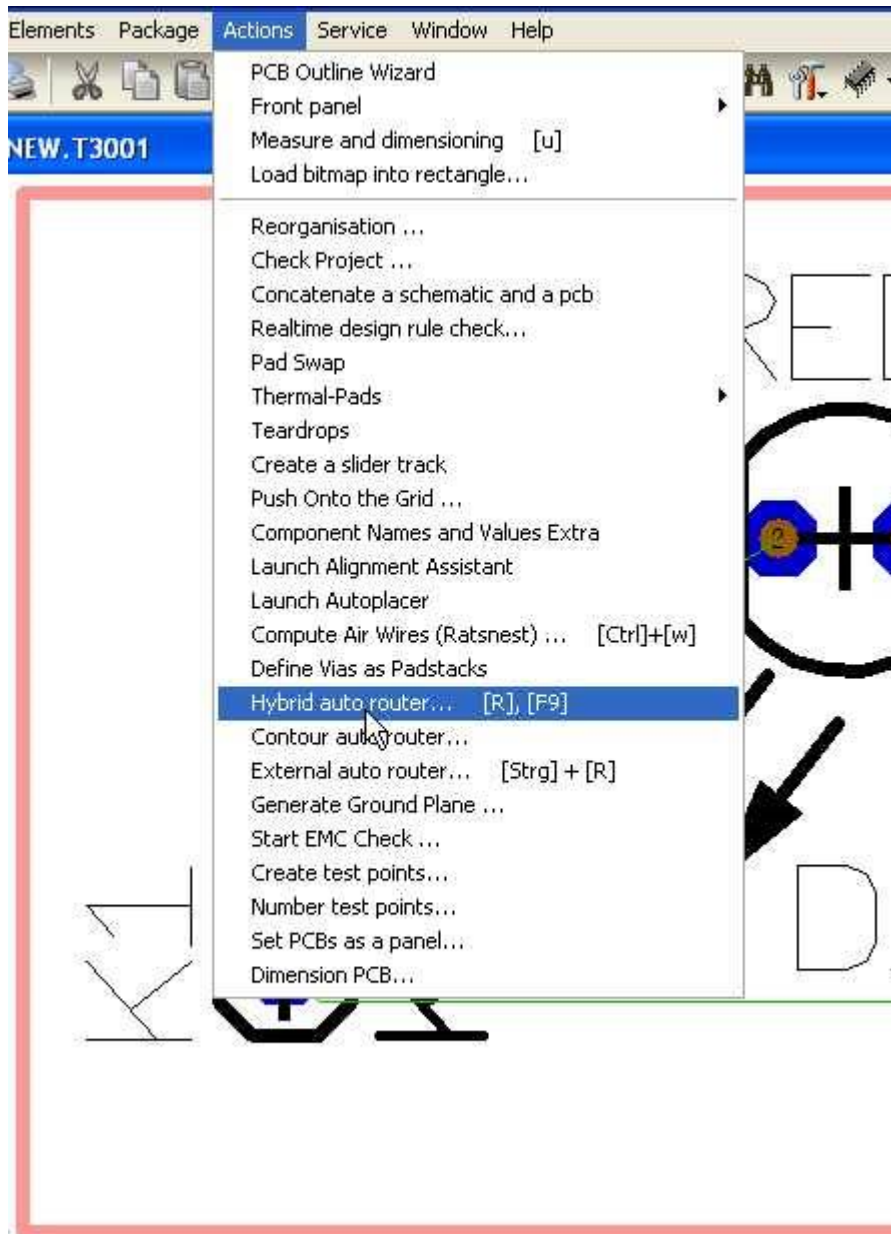

The opening dialog of the hybrid router has three sections divided by tabs. First the section "Signals".

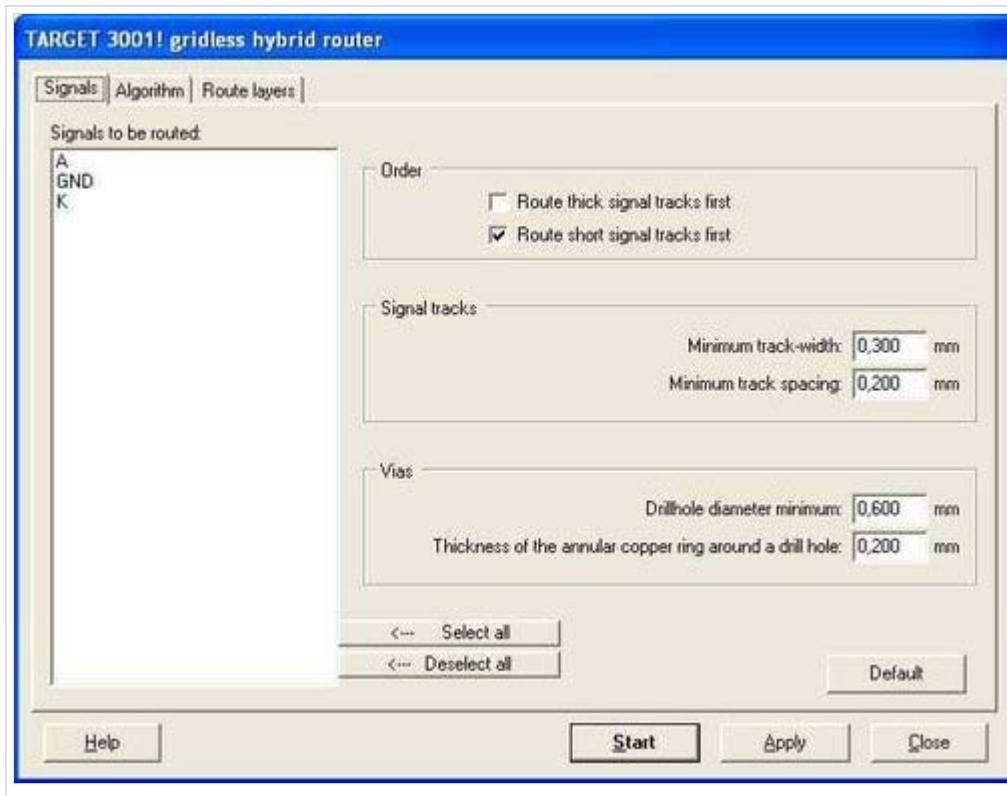

Now choose from the list one or more or all signals. If you select none, all are routed.

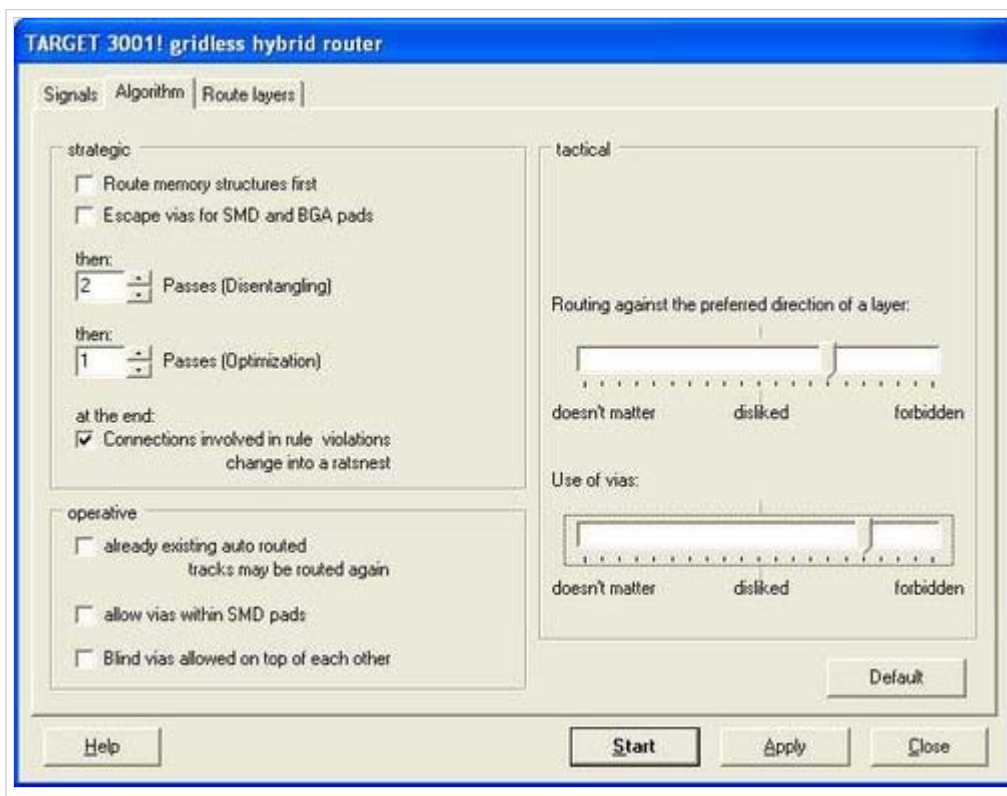

The second tab allows "strategic", "operative" and "tactical" settings. In the strategic area we leave the default settings with "two passes of disentangling" and "one pass of optimization". In the tactical area we place the slider between "disliked" and "forbidden". The third tab allows the assignment of certain signals to certain routing layers. We enter: "Copper bottom" (Layer 2) is available for all signals, "Copper top" (Layer 16) is blocked for all signals. Click on each layer line at the left to set their availability.

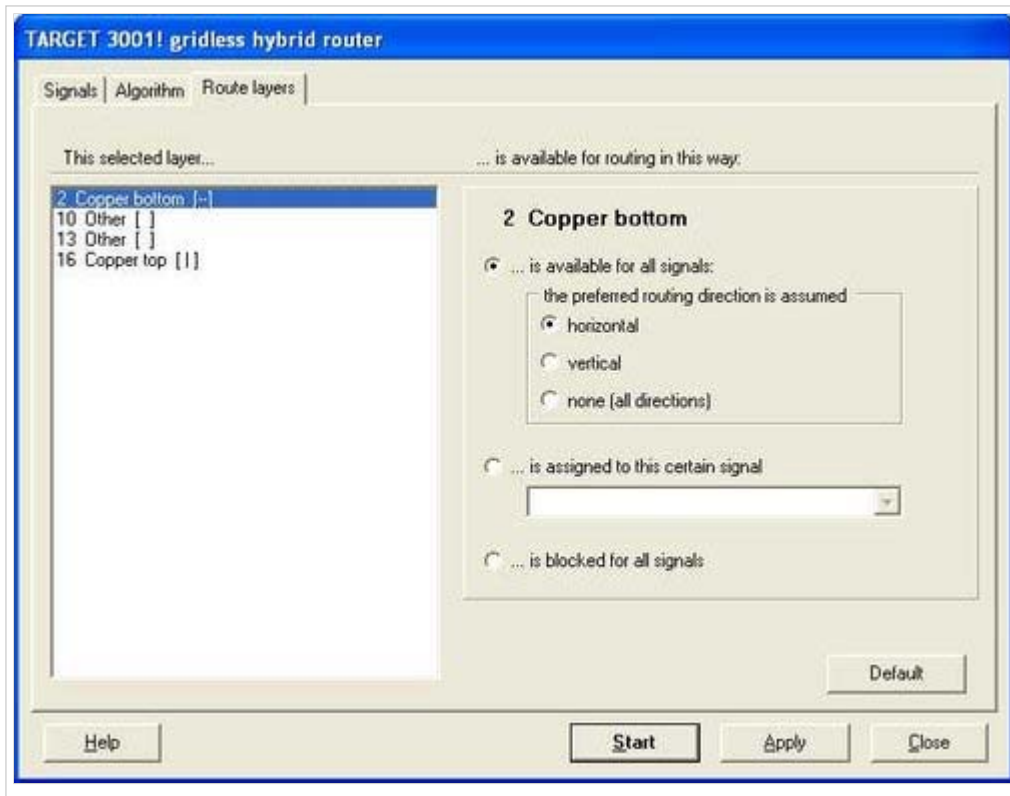

Now watch the router at his work...

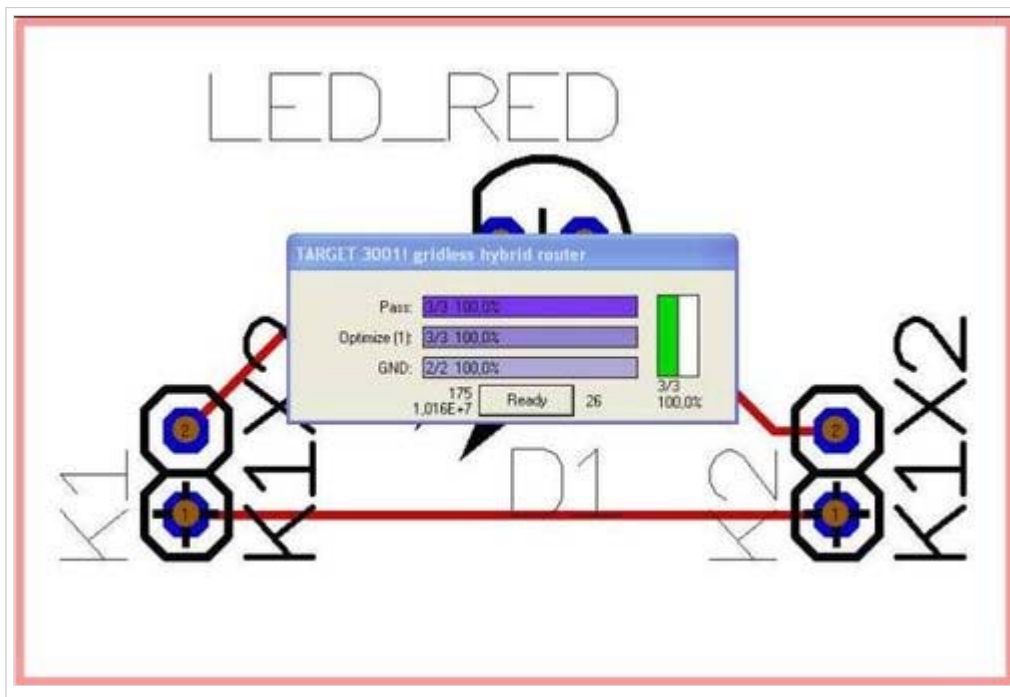

...and expect the following result:

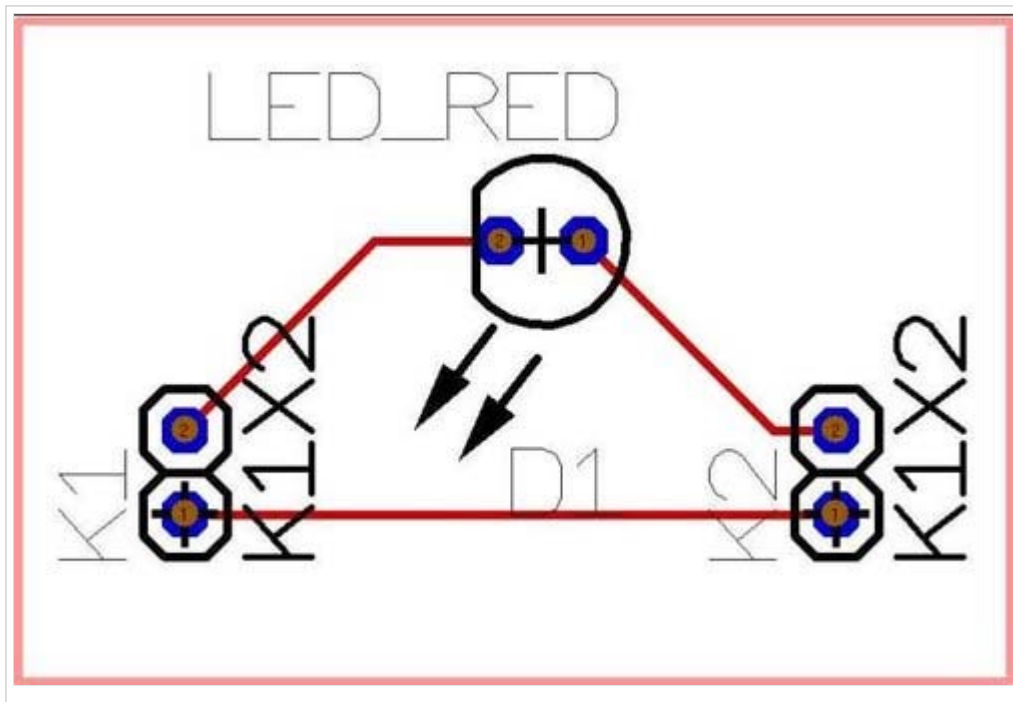

Next Step
One step back

[Back to the overview](#)

Retrieved from "http://server.ibfriedrich.com/wiki/ibfwikien/index.php?title=Place_tracks"

Categories: Layout

IBF-Intern:

- This page was last modified 13:53, 15 January 2009.
- This page has been accessed 4,686 times.